



Assembly Instructions

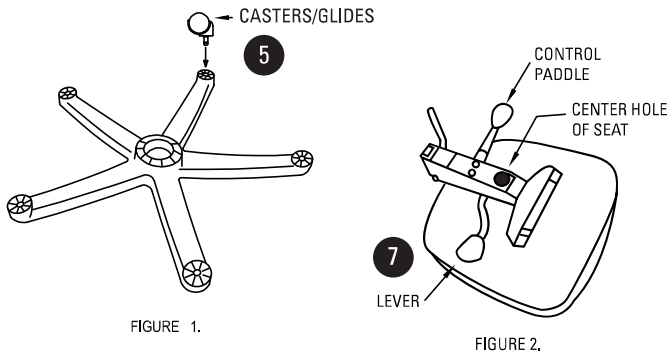

FIGURE 1.

FIGURE 2.

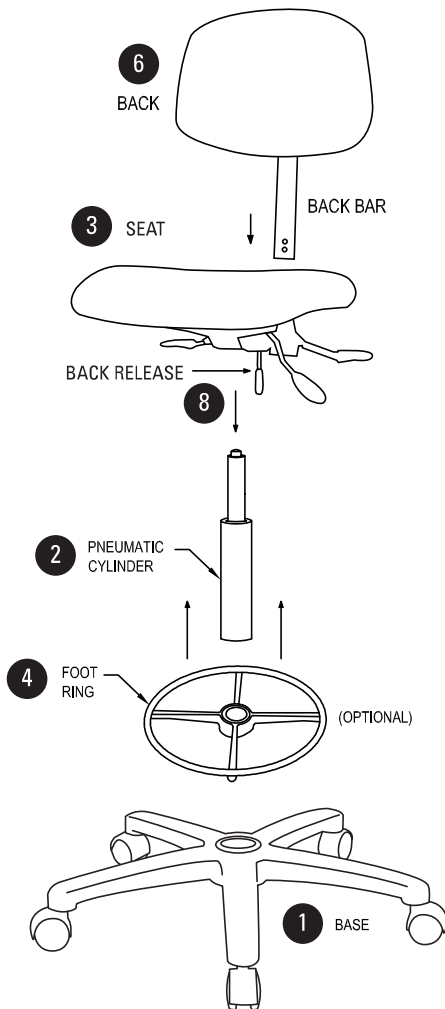
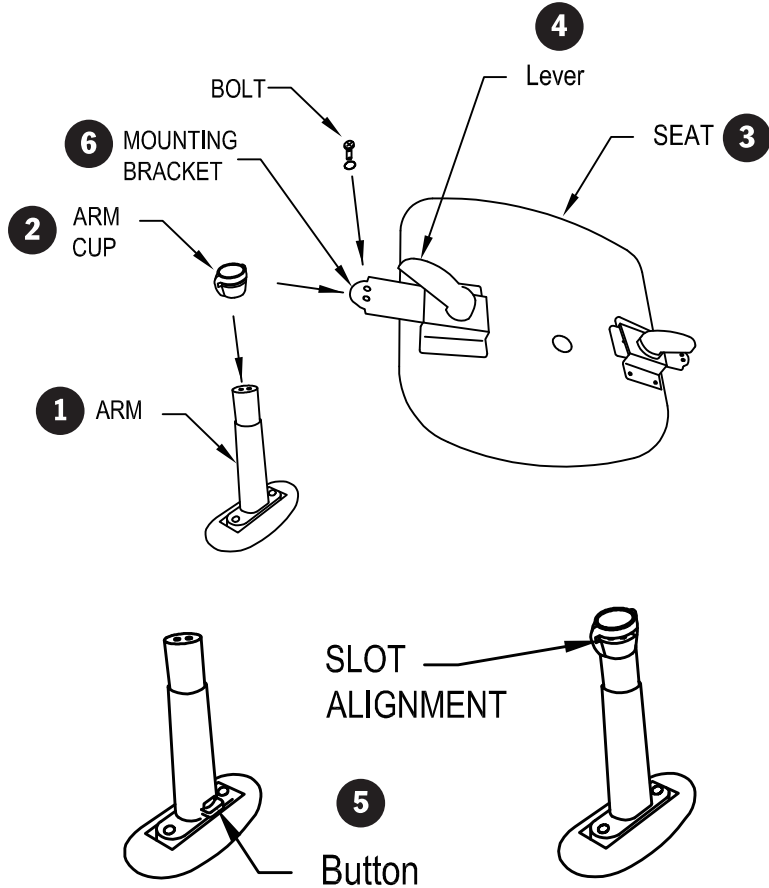

FIGURE 3.

- 1) Remove base, back/back bar, pneumatic cylinder, seat, foot ring (if included) and casters/glides from box.
- 2) Place base (1) upside down and insert casters/glides (5) (see figure 1).
- 3) Slide **optional** foot ring (4) over bottom pneumatic cylinder (2). The foot ring rests atop spokes. Make sure spokes face the floor.
- 4) Flip the base so casters/glides are on the floor and insert pneumatic cylinder (2) as shown in (figure 3) into center hole of base with colored button up. Lightly push down. Adjust foot ring to desired height.
- 5) Align the center hole of the underside of the seat assembly (3) with the top of the pneumatic cylinder (2) and lightly push down. Kneel on the seat to hold it together. This will press the base, pneumatic cylinder and seat together. (Underside of the seat is shown in Figure 2)
- 6) Lift the back release. Insert back bar through the control channel slot. Adjust the height of the seat back for comfort and push the back release lever down to lock the bar in place. Once locked, push the enclosed safety button into the lower hole of back bar, flat side out.
- 8) Adjust the seat back to the desired angle using the control lever located on the side of the seat. You can adjust the height of the back by lifting the back release up. Push the back release (8) down to lock the bar in place.
- 9) To raise the height of your chair, take your weight off of the chair and pull up on the lever (7) on the underside of the seat and adjust.
- 10) To lower the height of your chair you must be seated with your weight on the seat, lift up on lever (7).



Assembly Instructions



- 1) Remove the two bolts from the (1) arm.
- 2) Align the open slot of the (2) arm cup so that it is even with the bottom of the cylinder of (1) arm.
- 3) With the (3) seat upside down, align the slot of the (2) arm cup with the (6) mounting bracket. Attach with the two bolts. (Note: Make sure that the (5) button is facing away from the (3) seat.) Repeat steps for opposite side.
- 4) You can adjust the arms in and out by loosening (4) lever and sliding the arm in or out. When adjusted to desired location, tighten (4) lever.
- 5) You can adjust the arms up or down by pulling up on (5) button, adjust to desired height and then release (5) button.



Assembly Instructions **** Initial Installation must be completed from the bottom of the cylinder ****

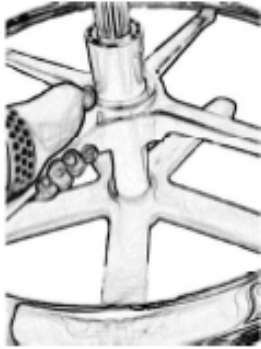

Unlock the foot ring by pushing the top of the inner center hub down.

Adjust the height to the appropriate height.

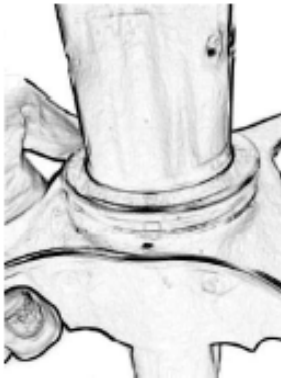

Lock the foot ring in place by pushing on the spokes until the inner center hub extends approximately ½" from the outer center hub.

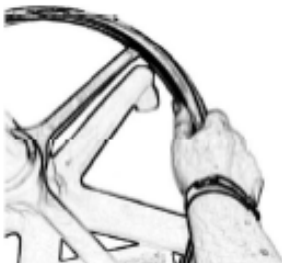

To fully lock, put pressure alternatively on the outer ring sides.